

# MODEL 796CALR MEDIUM DUTY CAM ADJUSTED LIVE ROLLER

24 HOUR SHIPMENTS INCLUDE ALL 1-FOOT INCREMENTS 6'-0" TO 100'-0"



Conveyor shown with optional supports

Roach 796CALR is ideally suited for side loading, unloading or temporary accumulation. Its unique cam allows tread roller drive pressure to be adjusted in only seconds.

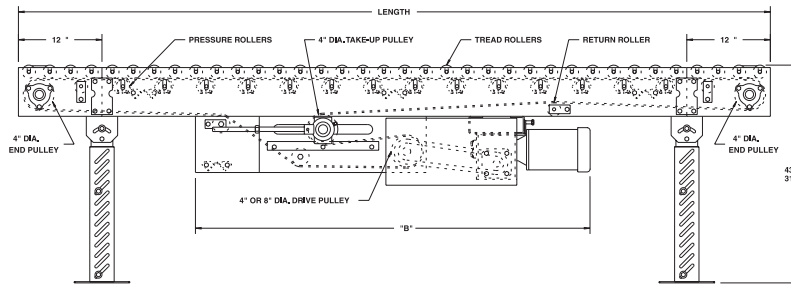
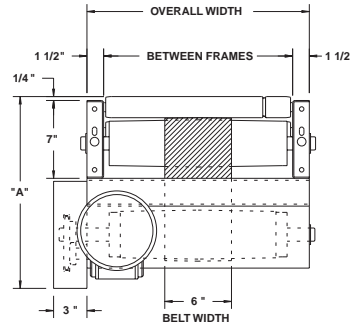

HP@ 60 FPM	"A" MAX		"B" MAX	
	4" DRV.	8" DRV.	4" DRV.	8" DRV.
1/3	16-5/8"	17-5/8"	58-5/32"	58-5/32"
1/2	16-5/8"	17-5/8"	58-5/32"	58-5/32"
3/4	17"	17-5/8"	58-25/32"	58-25/32"
1	17-1/4"	17-5/8"	59-17/32"	59-17/32"
1-1/2	18-1/8"	18-1/8"	61-21/32"	61-21/32"
2	19"	19"	62-21/32"	62-21/32"

## SPECIFICATIONS

**TREAD ROLLERS:** 1.9" dia. x 16 ga. steel rollers, model 196S.

**PRESSURE ROLLERS:** 1.9" dia. x 16 ga. steel, model 196S, cam adjustable.

**BELTING:** 6" wide black PVC-120 COS.

**CENTER DRIVE:** Reversible drive with 24" integral belt take-up. For units under 8'-0" overall length, drive components must be stacked. Consult factory for minimum unit elevation.

**SQUARING RODS:** Adjustable rods on underside of bed allow frame to be squared for improved belt tracking and are standard on all units over 30'.

**DRIVE PULLEY:** 4" dia. with 1-3/16" dia. shaft or 8" dia. with 1-7/16" dia. shaft, both crowned and fully lagged.

**END PULLEY:** 4" dia., crowned, with 1-3/16" dia. shaft.

**RETURN ROLLERS:** 1.9" dia. x 16 ga. steel, model 196S, adjustable.

**BED:** 7" x 1-1/2" x 12 ga. channel frame slotted for tread rollers to pop-out. When unit is installed at 7'-0" elevation or higher, rollers must be retained in conveyor frame. Specify desired elevation. Bed sections attached with couplings and floor supports.

**BEARINGS:** All pulley bearings are precision, heavy duty, lubricated, ball bearing units with cast iron housings.

**MOTOR DRIVE:** 1/3 HP, 230/460/3, 60 cycle, ODP right angle gear motor.

**ROLLER CHAIN:** Drive pulley is driven by No. 50 roller chain for 1-1/2 HP or less and No. 60 chain on larger drives. Chain take-up provided on motor base.

**SPEED:** 60 FPM, constant.

**ELECTRICAL CONTROLS:** Optional.



### WARNING

Pop-out rollers should be retained in frame if unit is elevated to 7'-0" and above.

## SPECIFICATION TABLE

50'-0" lengths and under are equipped with 4" dia. drive pulley; over 50'-0" includes 8" dia. drive pulley

■ 24 hour shipment

CONVEYOR LENGTH			10'	20'	30'	40'	50'	60'	70'	80'	90'	100'	Deduct
BF	OAW	BELT	UNIT WEIGHTS (lbs.) with 3" Roller Center (For other centers, deduct weights below)										Per Foot
15"	18"	6"	489	755	1021	1287	1553	1819	2085	2351	2617	2883	27
19"	22"	6"	552	859	1167	1474	1781	2089	2396	2704	3011	3318	31
21"	24"	6"	584	912	1240	1568	1896	2224	2552	2880	3208	3536	33
25"	28"	6"	647	1016	1385	1755	2124	2494	2863	3232	3602	3971	37
27"	30"	6"	678	1068	1458	1848	2238	2629	3019	3409	3799	4189	39
33"	36"	6"	773	1225	1677	2129	2581	3033	3486	3938	4390	4842	45
39"	42"	6"	867	1381	1895	2410	2924	3438	3952	4467	4981	5495	51

Deduct the following weights (lbs.) for other than 3" centers

Tread Roller Centers	15" BF		19" BF		21" BF		25" BF		27" BF		33" BF		39" BF	
	Per 5'	Per 10'	Per 5'	Per 10'	Per 5'	Per 10'	Per 5'	Per 10'	Per 5'	Per 10'	Per 5'	Per 10'	Per 5'	Per 10'
4-1/2"	-23	-45	-28	-55	-30	-60	-35	-69	-37	-75	-45	-90	-53	-105
6"	-45	-90	-54	-108	-60	-120	-69	-138	-75	-150	-90	-180	-105	-210
9"	-63	-117	-75	-142	-84	-156	-94	-180	-105	-195	-126	-234	-147	-273
12"	-67	-135	-84	-164	-90	-180	-103	-207	-112	-225	-135	-270	-157	-315

## OPTIONAL EQUIPMENT

**END DRIVE:** Mounted underneath conveyor. Minimum possible height is 20" TOR for underneath mounted end drive. Belt take-up required for end drive (if substituting end drive for center drive).

**SIDE MOUNTED END DRIVE:** Provides overall conveyor height of 10".

**192S TREAD ROLLERS:** 1.9" dia. x 12 ga. steel tread rollers, model 192S, available in model 192CALR.

**GALVANIZED ROLLERS:** Both tread and pressure rollers available in galvanized steel, model 196G. Specify tread only or both tread and pressure rollers.

**AUXILIARY TAKE-UP:** Provides 24" of belt take-up. Specify location. See Power Accessories.

**SPEED:** Constant speed 3-120 FPM; DC variable speed; AC inverter variable speed. Other constant or variable speeds available. NOTE: CAPACITY CHANGES WITH SPEED.

**BELTING:** 6" wide black PVC-150; 12" wide PVC-120.

**GUARD RAILS:** 1-3/4" x 1" formed channel (model GC), adjusts horizontally to 8" wider than roller and vertically to 6" above roller; formed steel fixed (model FSG in 2", 4" and 6" heights; fixed channel (model FC); 1-1/2" angle (model GA1-1/2). See Conveyor Accessories.

**CEILING HANGERS:** 5/8" dia. threaded rod with hardware to attach rods to conveyor. Provides 6' clearance between ceiling and TOR (furnished in place of floor supports). See Conveyor Accessories.

**FLOOR SUPPORTS:** Supports, knee braces, casters and polytier supports available. See Conveyor Accessories.

**MOTORS:** Available through 3 HP in TEFC, explosion proof, dirty duty, brake motor, 115/230/1, 575/3, etc.

**ELECTRICAL CONTROLS:** Magnetic starter (one direction or reversible); One direction manual starter; Momentary start/stop push button station; Forward/reversing/stop push button station. Mounting and pre-wiring for units up to 12' long.



POP-OUT ROLLERS (some rollers raised for clarity)

