

# MODEL 196ZPA MEDIUM DUTY ZERO PRESSURE LIVE ROLLER ACCUMULATOR

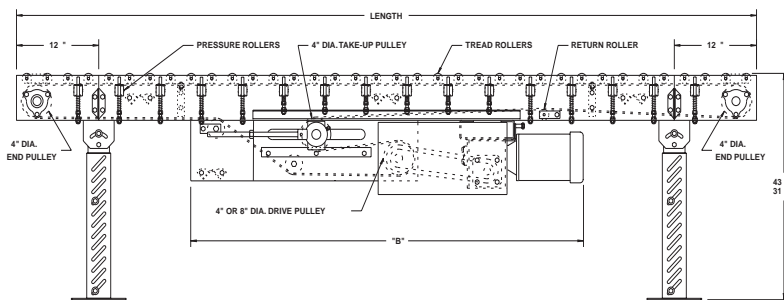

Conveyor shown with optional supports

Roach 196ZPA safely accumulates packages with zero back pressure utilizing zone singulation operation. Loads up to 125 lbs./ft. may be effectively handled with its unique design. This conveyor features NO minimum weight limitations. Sensor rollers are utilized to accumulate products with previously difficult minimal weight restrictions.

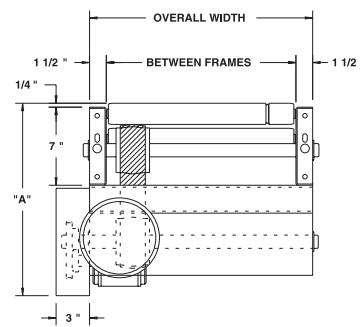

HP@ 60 FPM	"A" MAX		"B" MAX	
	4" DRV.	8" DRV.	4" DRV.	8" DRV.
1/3	16-5/8"	17-5/8"	58-5/32"	58-5/32"
1/2	16-5/8"	17-5/8"	58-5/32"	58-5/32"
3/4	17"	17-5/8"	58-25/32"	58-25/32"
1	17-1/4"	17-5/8"	59-17/32"	59-17/32"
1-1/2	18-1/8"	18-1/8"	61-21/32"	61-21/32"
2	19"	19"	62-21/32"	62-21/32"

## SPECIFICATIONS

**TREAD ROLLERS:** 1.9" dia. x 16 ga. steel, model 196G.

**PRESSURE ROLLERS:** 1.9" dia. x 16 ga. steel, model 196G.

**RETURN ROLLERS:** 1.9" dia. x 16 ga. steel, model 196G, adjustable.

**BELTING:** 2-1/4" wide "high strength" PVC-150 belt. \*NOTE: WHEN SLAVE DRIVING OTHER UNITS, OPTIONAL 6" WIDE PVC-120 DRIVE BELT MUST BE USED ON UNITS 20' LONG AND ABOVE.

**CENTER DRIVE:** Reversible drive with 24" integral belt take-up. For units under 8'-0" overall length, drive components must be stacked. Consult factory for minimum unit elevation.

**END PULLEY:** 4" dia., crowned, with 1-3/16" dia. shaft.

**DRIVE PULLEY:** \*4" dia. with 1-3/16" dia. shaft or 8" dia. with 1-7/16" dia. shaft, both crowned and fully lagged.

**SPEED:** 60 FPM, constant.

**BED:** 7" x 1-1/2" x 12 ga. channel frame slotted for tread rollers to pop-out. When unit is installed at 7'-0" elevation or higher, rollers must be retained in conveyor frame. Specify desired elevation. Bed sections attached with couplings and floor supports.

**SQUARING RODS:** Adjustable rods on underside of bed allow frame to be squared for improved belt tracking and are standard on all units over 30'.

**BEARINGS:** All pulley bearings are precision, heavy duty, lubricated, ball bearing units with cast iron housings.

**MOTOR DRIVE:** 1/3 HP, 230/460/3, 60 cycle, ODP right angle gear motor.

**ROLLER CHAIN:** Drive pulley is driven by No. 50 roller chain for 1-1/2 HP or less and No. 60 chain on larger drives. Chain take-up provided on motor base.

**ELECTRICAL CONTROLS:** Optional.



### WARNING

Pop-out rollers should be retained in frame if unit is elevated to 7'-0" and above.

\*When using 2-1/4" wide drive belt, 4" dia. drive pulley supplied up to 20'-0" long; 8" dia. pulley supplied over 20'-0" unit lengths.

\*When using OPTIONAL 6" wide drive belt, 4" dia. drive pulley supplied up to 50'-0" long; 8" dia. pulley supplied over 50'-0" unit lengths.

\*When slave driving other units, OPTIONAL 6" wide drive belt must be used on units 20'-0" and above.

## SPECIFICATION TABLE

■ 24 hour shipment

CONVEYOR LENGTH		10'	20'	30'	40'	50'	60'	70'	80'	90'	100'	Deduct	
BF	OAW	UNIT WEIGHTS (lbs.) with 3" Roller Centers (For other centers, deduct weights below)										Per Foot	
15"	18"	2-1/4"	460	720	979	1239	1498	1758	2017	2277	2536	2796	26
19"	22"	2-1/4"	515	816	1116	1417	1718	2018	2319	2619	2920	3221	30
21"	24"	2-1/4"	543	864	1185	1506	1827	2148	2470	2791	3112	3433	32
25"	28"	2-1/4"	598	960	1322	1685	2047	2409	2771	3133	3495	3858	36
27"	30"	2-1/4"	626	1008	1391	1774	2156	2539	2922	3305	3687	4070	38
33"	36"	2-1/4"	708	1153	1597	2041	2485	2930	3374	3818	4263	4707	44
39"	42"	2-1/4"	791	1297	1803	2309	2815	3320	3826	4332	4838	5344	51

Deduct the following weights (lbs.) for other than 3" centers

Tread Roller Centers	15" BF		19" BF		21" BF		25" BF		27" BF		33" BF		39" BF	
	Per 5'	Per 10'	Per 5'	Per 10'	Per 5'	Per 10'	Per 5'	Per 10'	Per 5'	Per 10'	Per 5'	Per 10'	Per 5'	Per 10'
4-1/2"	-23	-45	-28	-55	-30	-60	-35	-69	-37	-75	-45	-90	-53	-105
6"	-45	-90	-54	-108	-60	-120	-69	-138	-75	-150	-90	-180	-105	-210

## OPTIONAL EQUIPMENT

**END DRIVE:** Mounted underneath conveyor. Minimum possible height is 20" TOR for underneath mounted end drive. Belt take-up required for end drive (if substituting end drive for center drive).

**SIDE MOUNTED END DRIVE:** Provides overall conveyor height of 10".

**BELTING:** 6" wide black PVC-120; 6" wide black PVC-150; 12" wide PVC-120.

**GUARD RAILS:** 1-3/4" x 1" formed channel (model GC), adjusts horizontally to 8" wider than roller and vertically to 6" above roller; formed steel fixed (model FSG in 2", 4" and 6" heights; fixed channel (model FC); 1-1/2" angle (model GA1-1/2). See Conveyor Accessories.

**CEILING HANGERS:** 5/8" dia. threaded rod with hardware to attach rods to conveyor. Provides 6' clearance between ceiling and TOR (furnished in place of floor supports). See Conveyors Accessories.

**FLOOR SUPPORTS:** Supports, knee braces, casters and polytier supports available. See Conveyor Accessories.

**SPEED:** Constant speed 3-120 FPM; DC variable speed; AC inverter variable speed. Other constant or variable speeds available. NOTE: CAPACITY CHANGES WITH SPEED.

**GALVANIZED ROLLERS:** Both tread and pressure rollers available in galvanized steel, model 196G. Specify tread only or both tread and pressure rollers.

**192S TREAD ROLLERS:** 1.9" dia. x 12 ga. steel tread rollers, model 192S, available in model 192VP.

**AUXILIARY TAKE-UP:** Provides 24" of belt take-up. Specify location. See Power Accessories.

**MOTORS:** Available through 3 HP in TEFC, explosion proof, dirty duty, brake motor, 115/230/1, 575/3, etc.

**ELECTRICAL CONTROLS:** Magnetic starter (one direction or reversible); One direction manual starter; Momentary start/stop push button station; Forward/reversing /stop push button station. Mounting and pre-wiring for units up to 12' long.



VARIABLE PRESSURE ADJUSTMENT

